

Boot-Sep™

Natural Gas Production & Gathering Industry Filter Separator

The Boot-Sep GX is designed and constructed in accordance with ASME, comes with genuine PECO FibrSep GX elements installed and has a quick opening closure. Designed specifically for the demands of the natural gas production and gathering industry you can expect it to be ready go, easy to install and maintain. Whether you're building a new gathering system or trying to improve the performance of existing compressors and processing equipment, the Boot-Sep GX is the most convenient and economical device for protecting your investment from scale, rust, slag, hydrocarbon liquids, brine and other contaminants.

When you need it, where you need it, the Boot-Sep GX filter separator will get the job done. We keep three sizes in inventory ready for same day shipment at highly competitive prices.

Call PECO today and have a Boot-Sep GX delivered tomorrow.

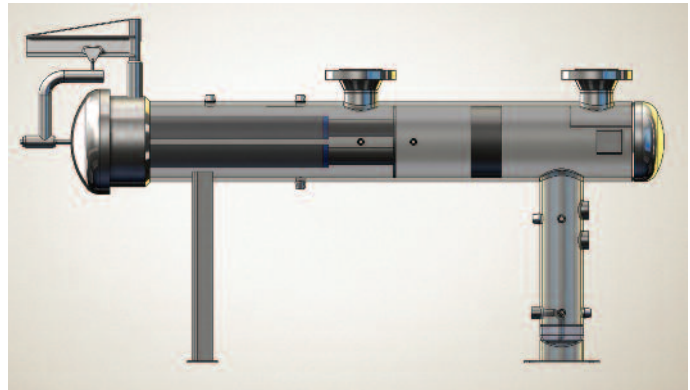
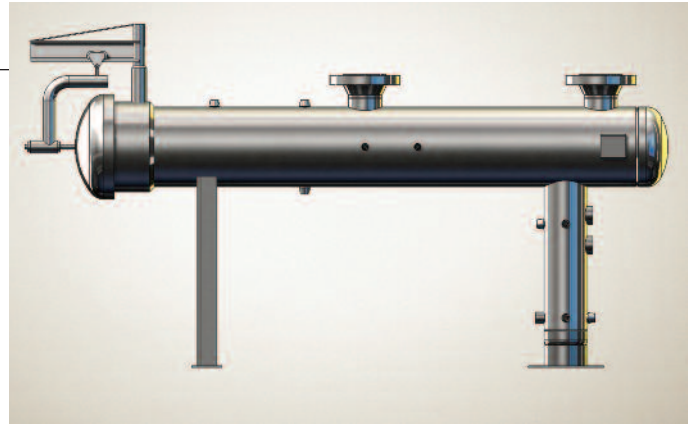

MATERIALS OF CONSTRUCTION

- **Pressure Retaining Parts** – Carbon Steel
- **Saddle Support and base plates** – Carbon Steel
- **Element support plate and risers** – Carbon Steel
- **Mesh pad** – Stainless Steel

APPLICATIONS

- **Compressor suction**
- **Contactors inlets**
- **Upstream of meters and valves**

FEATURES AND BENEFITS

- **Quick opening closure**
- **FibrSep GX Elements**
- **Instrument and valve connections**
- **In Stock**
- **Priced Right**
- **PECO support**

FEATURING  **SCHEDULED MAINTENANCE**

SIZES (upper barrel diameter)

- 12" ■ 16" ■ 24"

DESIGN

| Pressure | Temperature | Corrosion Allowance | Code |
|-----------|----------------|---------------------|--------------------------|
| 1440 psig | -20° to 100° F | 0 in. | ASME Section VII, Div. 1 |



Start Saving Money Today!

- Lower Price
- Enhanced Quality Product
- Direct Fiberglass Replacement



A Name You Know...Filters You Can Trust™

DIMENSIONS

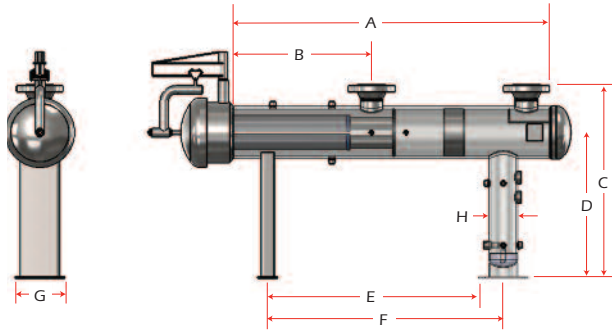

Vessel Dimensions

| O.D. [in.] | A [in.] | B [in.] | C [in.] | D [in.] | E [in.] | F [in.] | G [in.] | H [in.] |
|------------|---------|---------|---------|---------|---------|---------|---------|---------|
| 12.75 | 96 | 60 | 54.75 | 42.375 | 62.3125 | 68.3125 | 14 | 8.625 |
| 16 | 102 | 48 | 58.5 | 44 | 64 | 71.5 | 15 | 8.625 |
| 24 | 108 | 48 | 68 | 48 | 72 | 80 | 25 | 12.75 |

Nozzle Schedule

| Service | Qty. | Size [in.] | Rating | Type | Material |
|-----------------------|------|------------|--------|---------|---------------|
| Inlet (12 / 16 / 24) | 1 | 4 / 6 / 8 | 600# | ANSI RF | SA 105 |
| Outlet (12 / 16 / 24) | 1 | 4 / 6 / 8 | 600# | ANSI RF | SA 105 |
| Sight Glass | 2 | 3/4 | 3000# | FNPT | SA 105 |
| Auto Dump | 1 | 1 | 3000# | FNPT | SA 105 |
| Drains | 1 | 1 | 3000# | FNPT | SA 105 |
| LLC | 1 | 2 | 3000# | FNPT | SA 105 |
| DPI | 2 | — | 3000# | FNPT | SA 105 |
| PSV | 1 | 1 | 3000# | FNPT | SA 105 |
| Blow Down | 1 | 1 | 3000# | FNPT | SA 105 |
| Clean-out | 2 | 2 | 3000# | FNPT | SA 105 SA 105 |
| Aux. | 2 | 1 | 3000# | FNPT | |

PURCHASING INFORMATION

Model Numbers

- 12"** GPFS-12-1440-4
- 16"** GPFS-16-1440-6
- 24"** GPFS-24-1440-8



Walters Industrial Park / P.O. Box 640 / Mineral Wells, TX 76068
 Phone 940.325.2575 / 1.800.877.PECO / Fax 940.325.4622
 perryequipment.com / Email PECOElements@PECOFacet.com

Brought to you by PECOFacet
 a CLARCOR company

© 2009 PECOFacet
 PECOFacet has a policy of continuous
 product research and development
 and reserves the right to change design
 and specifications without notice.

FS-BS-TD-01 7/10